



 **metal**
p r o f i t



O Kompaniji...

- Osnovani 2014 godine, kao mala firma sa samo 5 uposlenika
- Broj uposlenih danas je 125
- Više od 95% naše proizvodnje je namjenjeno Njemačkom, Austrijskom i Švajcarskom tržištu
- Godišnje se preradi 950 tona lima, i isporuči više od 180.000 radnih sati
- Proizvodni kapaciteti se prostiru na više od 2.000 kvadratnih metara



Proizvodnja

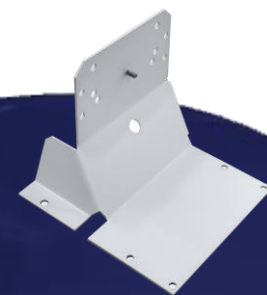
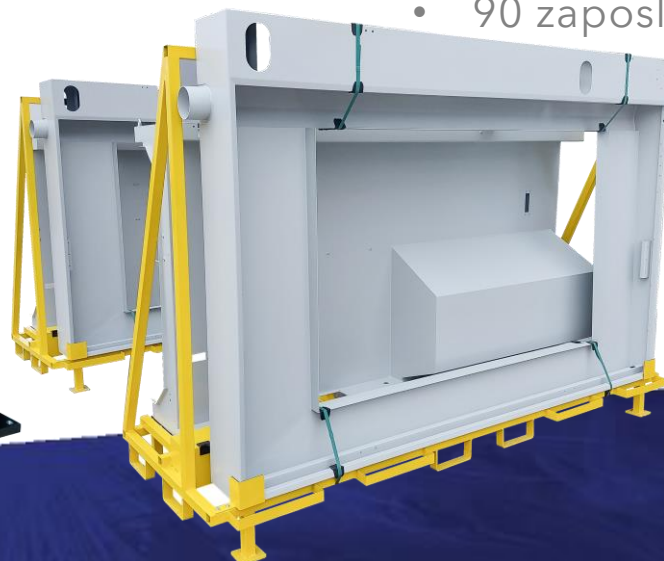

- Kućišta upravljačkih ormara i kućišta za mašine, dijelovi konstrukcija lakih mašina
- Kupno 4.000 kućišta godišnje
- Različiti dijelovi za mašine: osnovne ploče, olplata za mašine, poprečne grede, postolja.
- Kompletna konstrukcija mašina
- 90 zaposlenih u proizvodnom pogonu

- Laser Bystronic Bystar 3015 3000 x 1500 mm
- Laser Bystronic Byspeed 3105 3000 x 1500 mm
- 3 Prese za savijanje:
 - Beyeler 8 Achsen 100 t - 4 m
 - Prima Power Ep - 0520 56 t - 2 m
 - Prima Power Ep - 0520 135 t - 3,5 m
- MIG/TIG oprema za varenje
- Series 4 - M Six - Ton Press
- Sistem za lakiranje prahom (max. 4000 x 2200 x 1500 mm)

Mašinski park

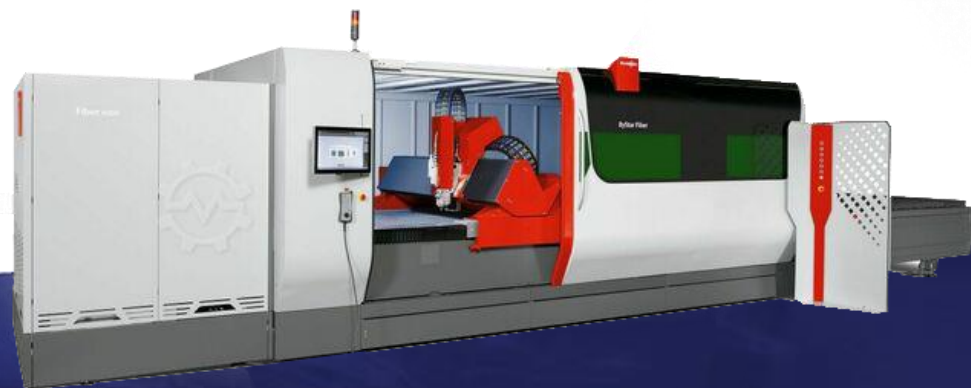

Sistem upravljanja proizvodnjom!

Mi u Metalprofit kompaniji mozemo pratiti kompletan proizvodni proces, od momenta dobijanja upita do finalizacije gotovog rješenja, kroz moderan informacijski sistem koji nam omogućava kompletnu vremensku sljedivost u proizvodnom procesu.

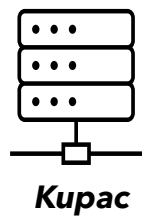

EDI Proces (upit - narudžba)

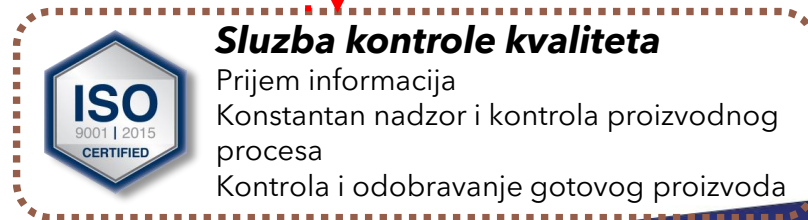
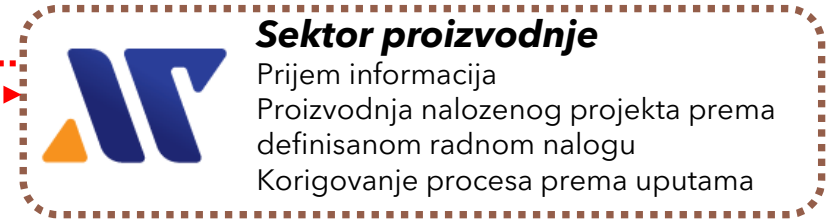
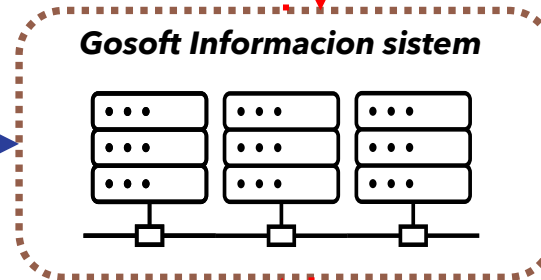
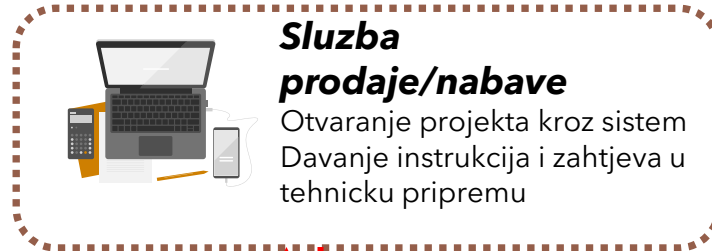

Production Control System



Sales/Supply department

- Setting the project through IS
- Giving instructions and demands to Technical department



Tech Department

- Elaboration of the plan and technical documentation
- Model making with certified tools
- Making a part list for the required project

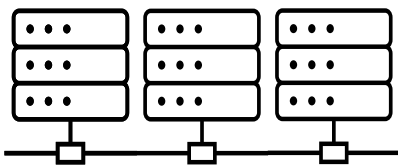

Gosoft Information system



Production Department

- Production of the ordered project according to defined work order
- Correcting the process according to the instructions



Quality Control Department

- Constant supervision and control of production process
- Control and approval of the finished product

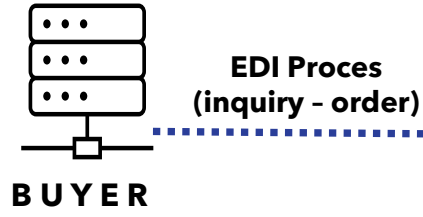

Usvojeni standardi upravljanja kvalitetom

CERTIFICATE



The Certification Body
of TÜV SÜD Management Service GmbH
certifies that



METALPROFIT d.o.o.

Titova 59
76240 Odžak
Bosnia-Herzegovina

has established and applies
a Quality Management System for

Processing of
sheets and other metal products by
plastic deformation and machining.

An audit was performed, Order No. 707121541.
Proof has been furnished that the requirements
according to

ISO 9001:2015

are fulfilled.

The certificate is valid from 2020-08-31 until 2023-08-30.

Certificate Registration No.: 12 100 60494 TMS.



Product Compliance Management
Munich, 2020-05-31



ISO certifikacija 9001:
2015 by TÜV Süd
München

Četiri zaposlena u
kontroli kvaliteta

Dva uposlena sa
aktivnim poznavanjem
Njemačkog jezika

Analiza
primjedbi i primjena
statističkih metoda

LEAN sistem rada
implementiran krajem
2019

Isporuka gotovog proi
zvoda sa
potpunom kontrolom
kvaliteta po ISO
standardu



- EU – granica sa direktnom putnom vezom sa Njemačkom, Austrijom i Švajcarskom
(780 km autoputa do Minhena)
- Briga o kupcima kroz službu Prodaje (PLM-Product Line Manager)
- KANBAN- isporuke na vrijeme
- Sedmicne isporuke ka kupcima
- Multi-jezični tim
- Priznavanje svih carinskih propisa EU kroz našu firmu: DLA DienstLeistungsAgent d.o.o Zagreb, Hrvatska (Uvoz – Izvoz iz EU – daljni razvoj)
- Upotreba razmjene podataka kao i sve relevantne metode obrade podataka,

References:



About us:



Ime Firme: Metalprofit d.o.o.
Godina osnivanja: 2014.
Adresa: Titova 59, 76 290 Odžak, Bosnia and Herzegovina
Identifikacioni broj: 4254143810000
PDV broj: 254143810000
Brojevi telefona: +387 31 941 455
Broj FAX-a: +387 31 941 460
E - mail: info@peo.ba
Web: www.metalprofit.ba



45°01'12.1"N 18°19'31.6"E

Our sister companies :

www.peo.ba **Proizvodnja Upravljačkih ormara**
110 workers

www.bpv.ba **Izrada I dizajn konstrukcija mašina**
20 workers

www.dla.hr **Firma za prodaju sa bazom u EU**
2 workers



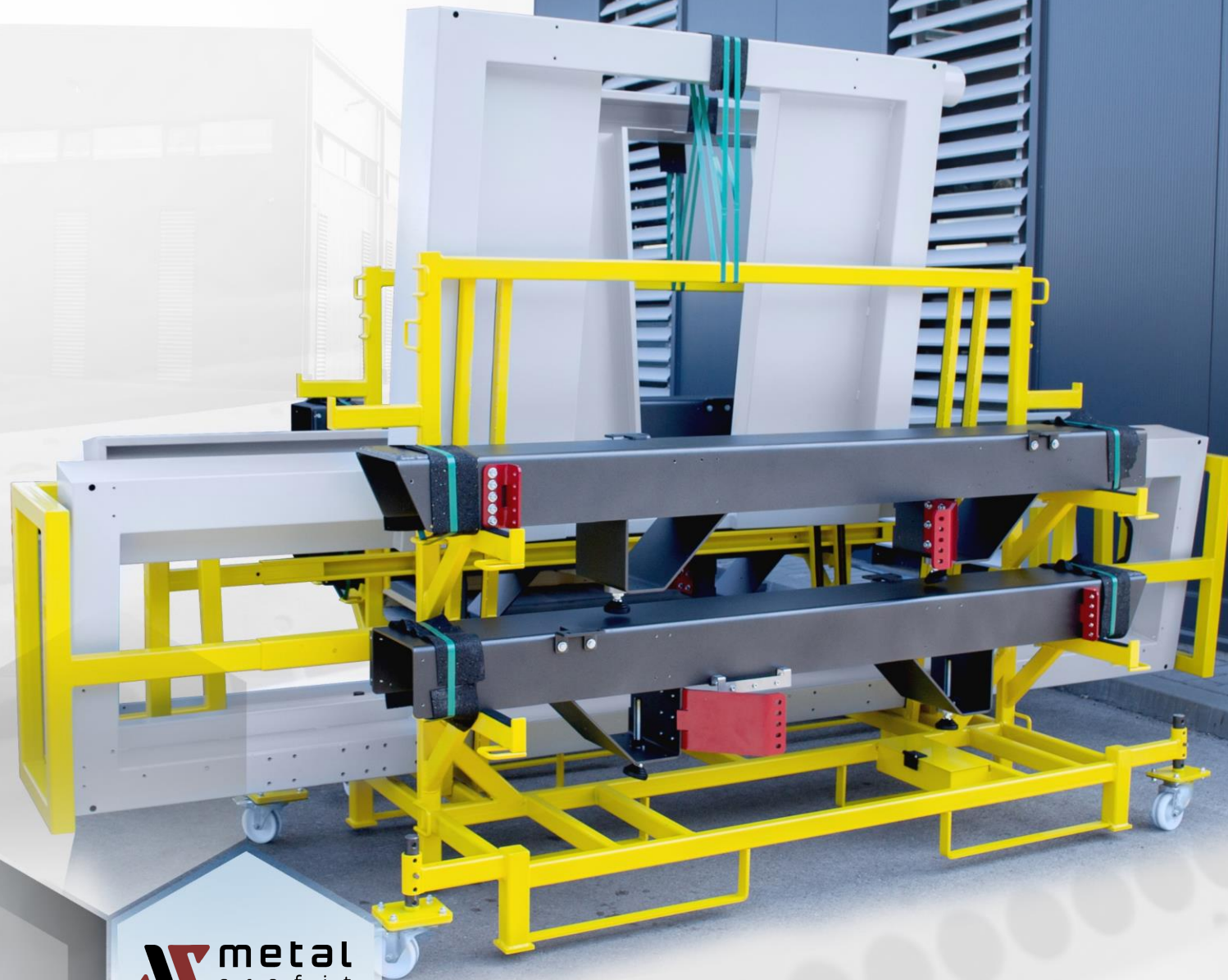

metal
profit





metal
profit



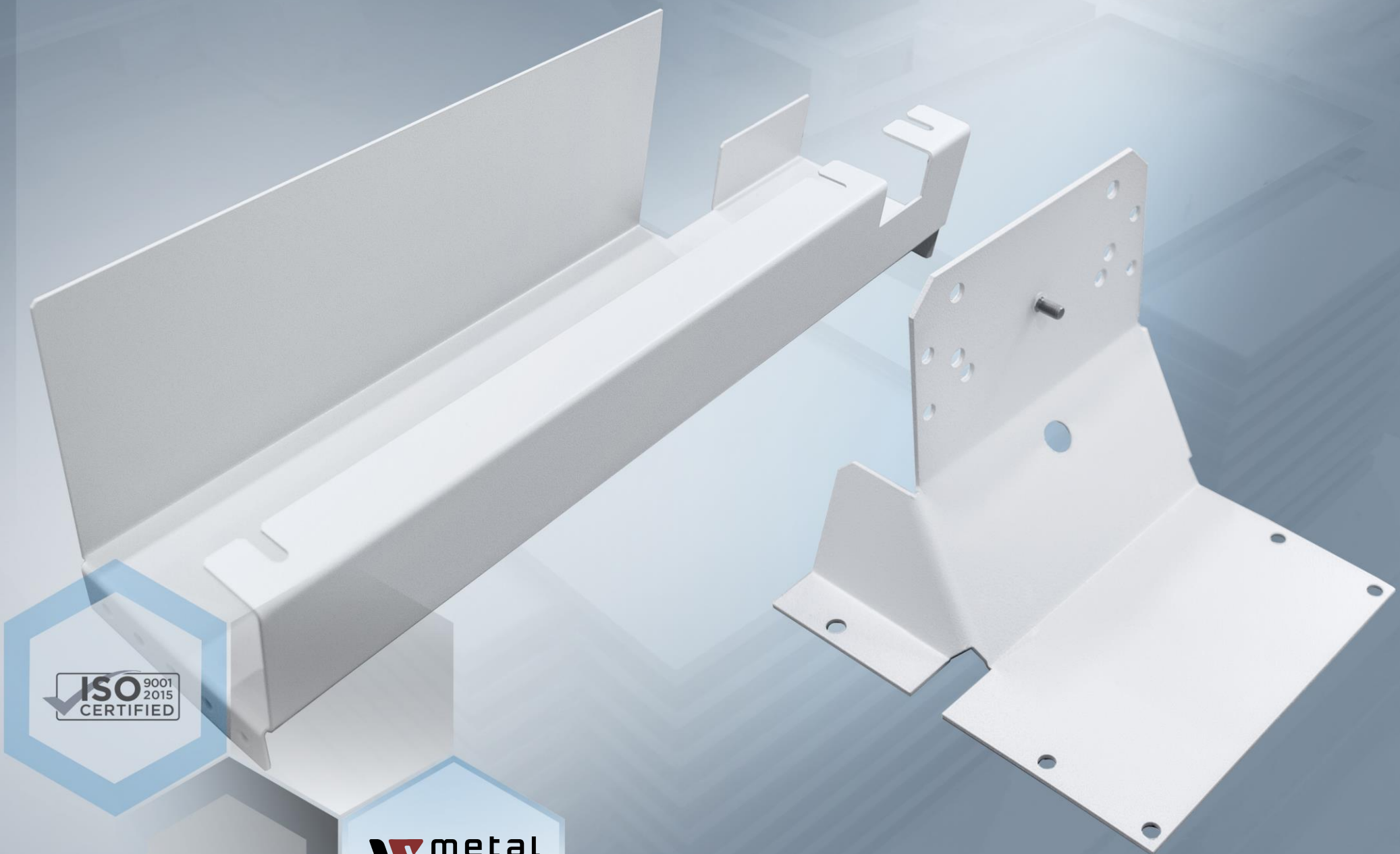

ISO 9001
2015
CERTIFIED

metal
profit

ISO
9001 | 2015
CERTIFIED



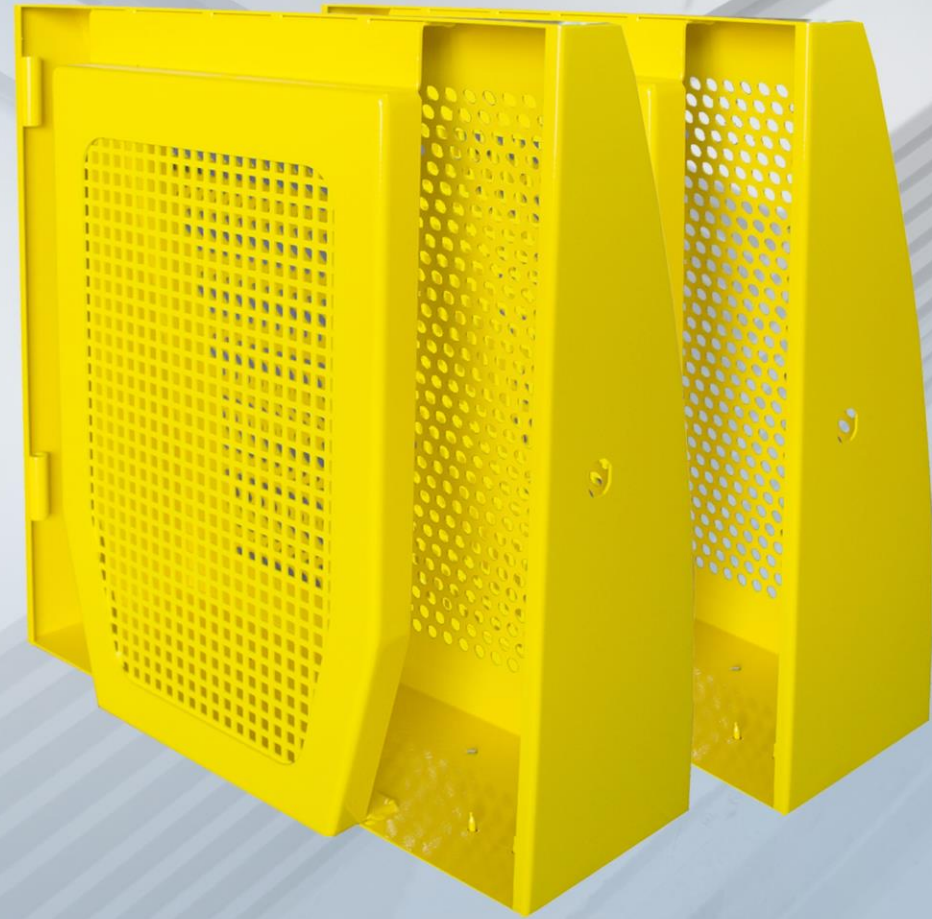
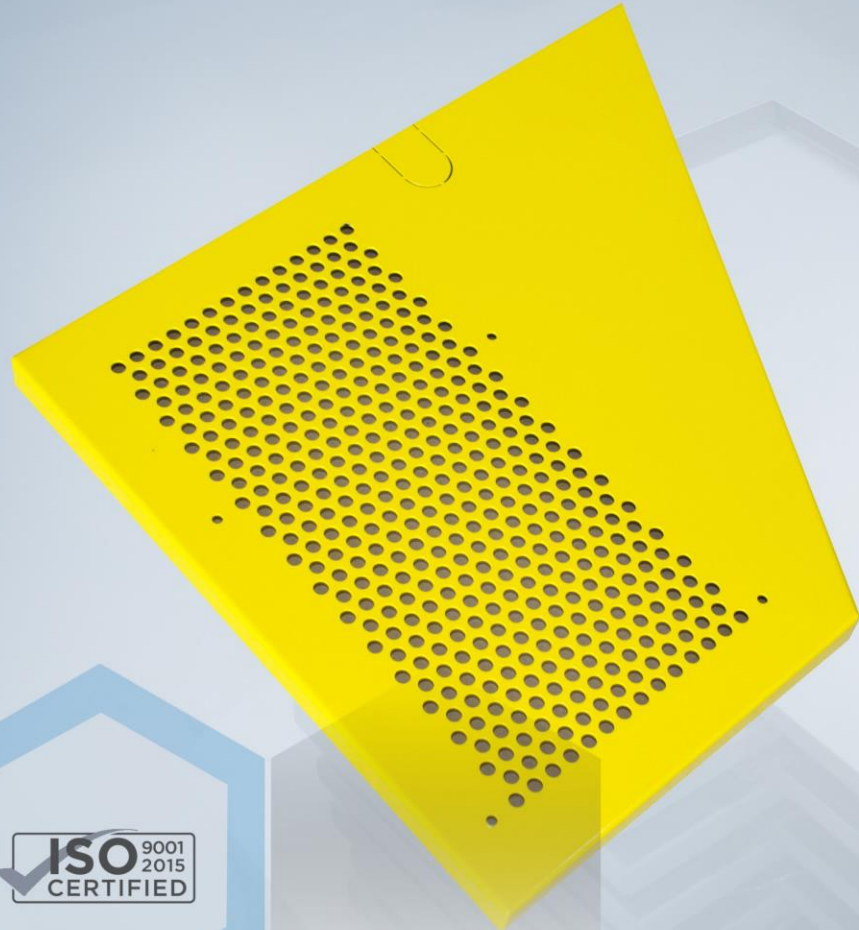



ISO 9001
2015
CERTIFIED

metal
profit

ISO
9001 | 2015
CERTIFIED



